**Paints and varnishes — Determination of
electrical conductivity and resistance**

*Peintures et vernis — Détermination de la conductivité et de la
résistance électriques*





COPYRIGHT PROTECTED DOCUMENT

© ISO 2012

All rights reserved. Unless otherwise specified, no part of this publication may be reproduced or utilized in any form or by any means, electronic or mechanical, including photocopying and microfilm, without permission in writing from either ISO at the address below or ISO's member body in the country of the requester.

ISO copyright office
Case postale 56 • CH-1211 Geneva 20
Tel. + 41 22 749 01 11
Fax + 41 22 749 09 47
E-mail copyright@iso.org
Web www.iso.org

Published in Switzerland

Contents

Page

Foreword	iv
1 Scope	1
2 Normative references	1
3 Terms and definitions	1
4 General	3
4.1 Measurement of the resistance	3
4.2 Avoidance of electrolysis and polarization effects	4
5 Apparatus	5
5.1 Measuring instrument	5
5.2 Measuring cell	5
6 Sampling	5
7 Procedure	5
7.1 Test conditions	5
7.2 Viscosity of test sample	6
7.3 Number of determinations	6
7.4 Measurement of the electrical resistance or the electrical conductivity	6
8 Expression of results	6
9 Precision	6
10 Test report	7
Annex A (normative) Calibration	8
Annex B (informative) Dependence of the conductivity on the measurement temperature	10
Bibliography	11

Foreword

ISO (the International Organization for Standardization) is a worldwide federation of national standards bodies (ISO member bodies). The work of preparing International Standards is normally carried out through ISO technical committees. Each member body interested in a subject for which a technical committee has been established has the right to be represented on that committee. International organizations, governmental and non-governmental, in liaison with ISO, also take part in the work. ISO collaborates closely with the International Electrotechnical Commission (IEC) on all matters of electrotechnical standardization.

International Standards are drafted in accordance with the rules given in the ISO/IEC Directives, Part 2.

The main task of technical committees is to prepare International Standards. Draft International Standards adopted by the technical committees are circulated to the member bodies for voting. Publication as an International Standard requires approval by at least 75 % of the member bodies casting a vote.

Attention is drawn to the possibility that some of the elements of this document may be the subject of patent rights. ISO shall not be held responsible for identifying any or all such patent rights.

ISO 15091 was prepared by Technical Committee ISO/TC 35, *Paints and varnishes*, Subcommittee SC 9, *General test methods for paints and varnishes*.

Paints and varnishes — Determination of electrical conductivity and resistance

1 Scope

This International Standard specifies a method for determining the electrical conductivity and the electrical resistance of coating materials. The conductivity is usually measured for water-borne paints and varnishes, including electrodeposition coating materials, and the resistance is usually measured for solvent-borne paints and varnishes. If required, the resistivity of the coating material is calculated from either of these measurements. The method is applicable to products having a conductivity less than 5 $\mu\text{S}/\text{cm}$, corresponding to a resistivity greater than 200 $\text{k}\Omega\cdot\text{cm}$.

The conductivity of coating materials influences their processibility in the presence of an electric field. This is particularly important for electrodeposition paints and coating materials which are processed electrostatically.

2 Normative references

The following referenced documents are indispensable for the application of this document. For dated references, only the edition cited applies. For undated references, the latest edition of the referenced document (including any amendments) applies.

ISO 1513, *Paints and varnishes — Examination and preparation of test samples*

ISO 3696, *Water for analytical laboratory use — Specification and test methods*

ISO 15528, *Paints, varnishes and raw materials for paints and varnishes — Sampling*

3 Terms and definitions

For the purposes of this document, the following terms and definitions apply.

3.1

electrical resistance

R

ratio of the potential difference along a conductor and the current through the conductor

NOTE Resistance is given by Ohm's law:

$$R = \frac{U}{I} \quad (1)$$

where

U is the potential difference;

I is the current.

The unit of electrical resistance is the ohm (Ω), given by:

$$1 \text{ ohm} = \frac{1 \text{ volt}}{1 \text{ ampere}}$$

The electrical resistance depends on the material of the conductor, its dimensions (length and cross-section) and its temperature.

**3.2
resistivity**

ρ
resistance per unit length of a material of unit cross-sectional area

NOTE Resistivity is given by Equation (2):

$$\rho = R \times \frac{A}{l} \quad (2)$$

where

A is the cross-sectional area of the conductor;

l is the length of the conductor.

The unit of resistivity is the ohm metre ($\Omega \cdot m$).

**3.3
conductance**

G
reciprocal of the resistance

NOTE Conductance is given by Equation (3):

$$G = \frac{1}{R} = \frac{I}{U} \quad (3)$$

The unit of conductance is the siemens (S):

$$1 \text{ S} = \frac{1}{\text{ohm}} = \frac{1 \text{ ampere}}{1 \text{ volt}}$$

**3.4
electrical conductivity**

γ
reciprocal of the resistivity

NOTE Electrical conductivity is given by Equation (4):

$$\gamma = \frac{1}{\rho} = \frac{1}{R} \times \frac{l}{A} \quad (4)$$

The unit of electrical conductivity is the siemens reciprocal metre ($S \cdot m^{-1}$).

**3.5
cell constant**

c
quotient of the length and the cross-sectional area of a conductor

NOTE It is given by Equation (5):

$$c = \frac{l}{A} \quad (5)$$

From Equation (2), it can be seen that it corresponds to the ratio of the resistance to the resistivity of the conductor material.

For the determination of the resistivity by resistance measurement, this geometrical factor, i.e. the cell constant of the measurement assembly, will need to be known.

Cell constants are given in reciprocal centimetres (cm^{-1}).

4 General

4.1 Measurement of the resistance

The resistance may be determined by

- measurement of the current through a sample and the voltage acting on the sample;
- or
- comparison of the measured resistance with a reference resistance.

For the current/voltage measurement, usually a constant pre-determined voltage is applied to the sample, and the current is measured with a suitable measuring instrument (e.g. a moving-coil instrument or a digital instrument). The resistance is then calculated from Equation (1). See Figures 1 to 3.

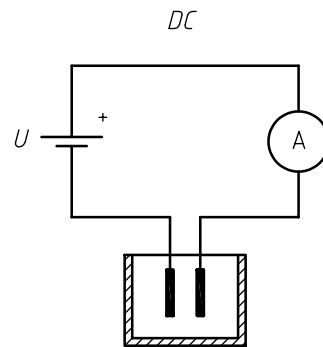

Figure 1 — Direct-current measurement

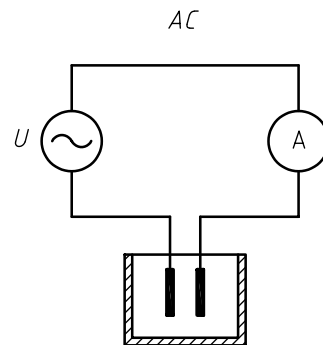

Figure 2 — Alternating-current measurement — Two-electrode cell

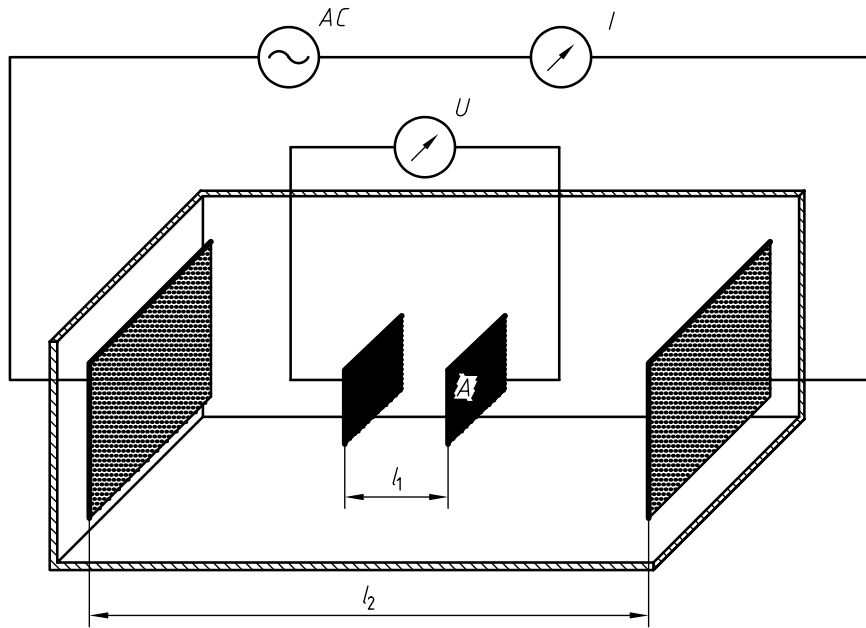
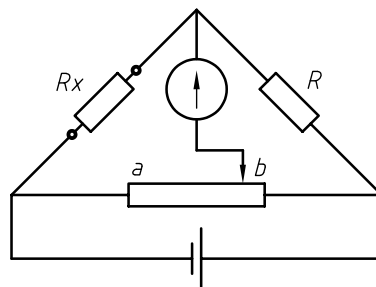

Figure 3 — Alternating-current measurement — Four-electrode cell

To compare the resistance of the sample with a reference resistance, a bridge circuit is used in which the resistances are balanced so that the bridge current becomes zero. The resistance of the sample is calculated from the ratio of the resistances of the bridge circuit. Because the bridge current is zero, errors which can result from the existence of a load on the voltage source when the voltage/current measurement method is used are avoided. The only contributions to the overall measurement error are any uncertainty in the reference resistance and any uncertainty in the adjustable resistance. See Figure 4.



$$R_x = R \times \frac{a}{b}$$

Figure 4 — Wheatstone bridge

4.2 Avoidance of electrolysis and polarization effects

In order to avoid electrolysis or polarization effects which would falsify the measurement, measurements of the resistance are usually carried out using alternating current. The frequency of the voltage applied to the measuring cell should, however, be as low as possible in order to minimize the contribution made by the reactance of the measuring cell, which acts as a capacitor.

5 Apparatus

5.1 Measuring instrument

Use a resistance- or conductivity-measuring instrument calibrated as described in Annex A.

5.2 Measuring cell

The measuring cell consists of electrodes insulated from each other, with a known cell constant. The electrodes should preferably consist of a material that is easy to clean and inert (e.g. stainless steel, platinum, graphite, titanium) in order to make sure that the measurement will not be invalidated by changes in the electrodes. For examples of suitable electrodes, see Figure 5. It is important to ensure that the measuring cell is completely immersed in the liquid. The exact depth will depend on the type of electrode.

The cell geometry shall be chosen so that the possibility of contamination by dirt is minimized.

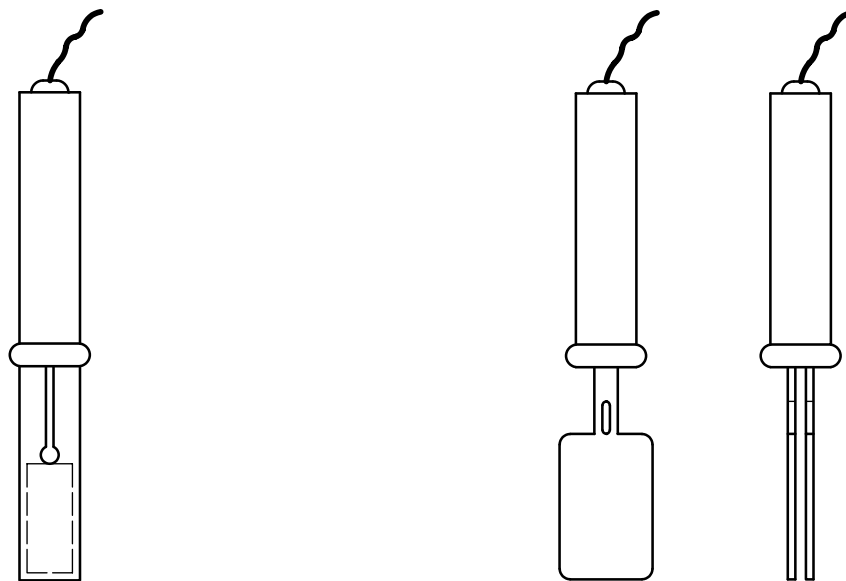

a) Measuring cell with cylinder electrodes

b) Measuring cell with plate electrodes

Figure 5 — Examples of measuring cells

6 Sampling

Take a representative sample of the product to be tested, as described in ISO 15528.

Examine and prepare each sample for testing, as described in ISO 1513.

7 Procedure

7.1 Test conditions

Carry out the test at a temperature of $(25 \pm 1) ^\circ\text{C}$, unless otherwise agreed. The deviation from any agreed temperature shall also be not more than $\pm 1 ^\circ\text{C}$.

The dependence of the conductivity on the measurement temperature is shown in Annex B.

7.2 Viscosity of test sample

The test is usually carried out at the same viscosity as that of the product under test when it is ready for use. The solvent used to adjust the viscosity, if this is necessary, shall be agreed between the interested parties.

7.3 Number of determinations

Make at least three individual measurements on the product under test.

7.4 Measurement of the electrical resistance or the electrical conductivity

Take the required quantity of the paint sample and immerse the electrodes in it, avoiding the formation of bubbles. If required, homogenize the material before doing this.

Prior to the measurement, check the measuring cell for cleanliness and remove any particles of dirt. Connect the measuring cell to the measuring instrument. For measurements using a direct-current measuring instrument, e.g. a Wheatstone bridge, read the value after a waiting time of 10 s in order to allow the electrical potential to become constant. For measurements using an alternating-current measuring instrument, read the value after an agreed waiting time.

When using continuously measuring instruments, the value shall only be read if it is constant for more than 20 s.

Immediately after the test, thoroughly clean the measuring cell.

8 Expression of results

Calculate the mean of the at least three individual measurements made of the resistance or conductivity. If required, calculate the resistivity from this mean value, using Equation (2) if resistance measurements were made or Equation (4) if conductivity measurements were made. Examples of the calculation of the resistivity from the measurements are given below, using typical values.

EXAMPLE 1: Calculation of the resistivity from resistance measurements

Mean resistance reading, <i>R</i>	MΩ	1,22
Mean resistance reading, <i>R</i>	kΩ	1 220
Cell constant, <i>c</i>	cm ⁻¹	7,55 × 10 ⁻³
Resistivity, <i>ρ</i>	MΩ·cm	161,6
Resistivity, <i>ρ</i>	MΩ·m	1,62

EXAMPLE 2: Calculation of the resistivity from conductivity measurements

Mean conductivity reading, <i>γ</i>	μS/cm	1,375
Mean conductivity reading, <i>γ</i>	nS/cm	1 375
Cell constant, <i>c</i>	cm ⁻¹	0,8
Resistivity, <i>ρ</i>	MΩ·cm	0,727
Resistivity, <i>ρ</i>	MΩ·m	0,007 27

9 Precision

The precision depends on the method of measurement, the reference materials used for calibration and the product examined. Some typical precision values are given in Table 1. Examples of the conductivity and resistivity to be expected for certain products are given in Table 2.

Table 1 — Typical precision values

Conductivity	Resistivity	Repeatability limit (<i>r</i>)	Reproducibility limit (<i>R</i>)
> 5 $\mu\text{S/cm}$	< 200 $\text{k}\Omega\cdot\text{cm}$	8 % ^a	17 % ^a
5 $\mu\text{S/cm}$ to 0,062 5 $\mu\text{S/cm}$	200 $\text{k}\Omega\cdot\text{cm}$ to 16 $\text{M}\Omega\cdot\text{cm}$	No precision data available	No precision data available
< 0,062 5 $\mu\text{S/cm}$	> 16 $\text{M}\Omega\cdot\text{cm}$	12 % ^b	70 % ^b
^a As given in ASTM D4399 ^[3] . ^b As given in ASTM D5682 ^[4] .			

Table 2 — Examples of the conductivity and resistivity to be expected for selected liquids

Examples	Conductivity at 25 °C	Resistivity
Water as specified in ISO 3696: Grade 1	$\leq 0,1 \mu\text{S/cm}$	$\geq 10 \text{M}\Omega\cdot\text{cm}$
Grade 2	$> 0,1 \mu\text{S/cm}$ but $\leq 1 \mu\text{S/cm}$	$\geq 1 \text{M}\Omega\cdot\text{cm}$ but $< 10 \text{M}\Omega\cdot\text{cm}$
Grade 3	$> 1 \mu\text{S/cm}$ but $\leq 5 \mu\text{S/cm}$	$\geq 0,2 \text{M}\Omega\cdot\text{cm}$ but $< 1 \text{M}\Omega\cdot\text{cm}$
Electrodeposition paint	700 $\mu\text{S/cm}$ to 2 000 $\mu\text{S/cm}$	1,43 $\text{k}\Omega\cdot\text{cm}$ to 0,50 $\text{k}\Omega\cdot\text{cm}$
Solvent-containing varnish	1 nS/cm to 10 nS/cm	1 000 $\text{M}\Omega\cdot\text{cm}$ to 100 $\text{M}\Omega\cdot\text{cm}$

10 Test report

The test report shall contain at least the following information:

- all information necessary for identification of the product tested (manufacturer, product designation, batch number, etc.);
- a reference to this International Standard (ISO 15091);
- the test temperature;
- the solvent, if the sample was diluted;
- details of the measuring instrument and the measuring cell used for the test;
- the test result, as indicated in Clause 8;
- any deviation from the test method specified;
- any unusual features (anomalies) observed during the test;
- the date of the test.

Annex A (normative)

Calibration

A.1 Calibration of the electrodes

A.1.1 Method A: Calibration using reference materials

Calibrate using suitable reference materials covering the range of values which are expected for the products to be tested. The uncertainty in the conductivity of the reference materials shall be taken into account. The conductivities of a range of aqueous potassium chloride solutions, which may be used for calibration purposes, are given in Table A.1.

Table A.1 — Conductivity of aqueous potassium chloride solutions

Molality of potassium chloride solution mol·kg ⁻¹	Conductivity at 25 °C μS·cm ⁻¹	Standard measurement uncertainty %
1,0	108 620,00 ^a	±0,04 ^a
0,1	12 824,60 ^a	±0,04 ^a
0,01	1 408,23 ^a	±0,03 ^a
0,001	46,71 ^b	±0,30 ^b
0,000 1	16,00 ^b	±3,0 ^b

^a As given in Reference [1].

^b Measured at the Physikalisch-Technische Bundesanstalt (PTB) in Braunschweig, Germany. The increased uncertainty at low concentration levels reflects the influence of CO₂.

Calibration of plate electrodes and cylinder electrodes shall be carried out using a suitable conductivity-measuring instrument capable of measuring conductivities lying in the range of conductivities stated for the reference materials.

Method A is not suitable for materials having a conductivity which corresponds to a resistance ≤ 200 kΩ.

A.1.2 Method B: Determination of the cell constant

Determine the cell constant by measuring the cell geometry, i.e. the distance between the plates and the area of each of the plates in the case of a plate electrode and the cylinder diameter and height in the case of a cylinder electrode.

EXAMPLES

Cell constant, c , of a plate electrode:

$$c = \frac{l}{A} \tag{A.1}$$

where

l is the distance between the plates;

A is the area of each of the plates.

Cell constant, c , of a cylinder electrode:

$$c = \frac{\ln(r_e / r_i)}{2\pi h} \quad (\text{A.2})$$

where

r_e is the internal radius of the exterior cylinder;

r_i is the radius of the interior cylinder;

h is the height of the cylinder.

The contribution by this type of calibration to the uncertainty of the measurement is about $\pm 2,5$ %.

A.2 Calibration of the measuring instrument (without the electrodes)

Calibrate the resistance-measuring equipment using reference resistors covering the measurement range or send it to the instrument manufacturer for calibration.

Annex B (informative)

Dependence of the conductivity on the measurement temperature

The influence of temperature on conductivity measurements is given by Equation (B.1):

$$\gamma_{\theta} = \gamma_T \times \left[1 + \frac{\alpha}{100} \times (\theta - T) \right] \quad (\text{B.1})$$

where

- γ_{θ} is the conductivity measured at temperature θ ;
- T is the reference temperature;
- γ_T is the conductivity at the reference temperature;
- α is the temperature coefficient of conductivity.

Figure B.1 shows an example of this dependence, in which:

$T = 25 \text{ }^{\circ}\text{C}$;

$\gamma_T = 1 \text{ nS/cm}$ at $25 \text{ }^{\circ}\text{C}$;

$\alpha = 5 \text{ } \%/^{\circ}\text{C}$.

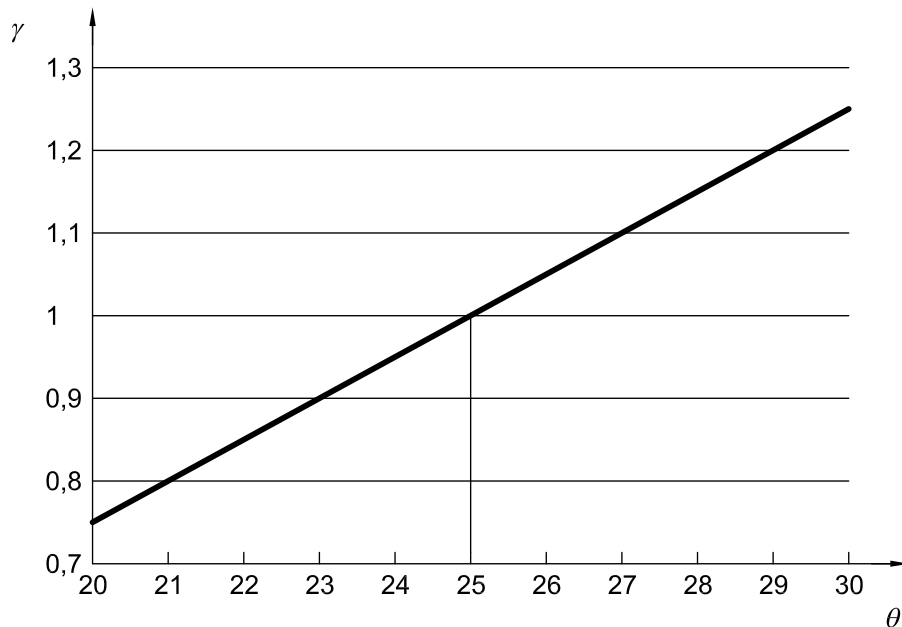

Key

- θ measurement temperature, in degrees Celsius;
- γ conductivity, in nanosiemens per centimetre.

Figure B.1 — Dependence of the conductivity, γ_{θ} , on the temperature, θ

Bibliography

- [1] *Pure Appl. Chem.*, Vol. 73, No. 11, pp. 1783-1793, 2001
- [2] ISO 7888, *Water quality — Determination of electrical conductivity*
- [3] ASTM D4399, *Standard Test Method for Measuring Electrical Conductivity of Electrocoat Baths*
- [4] ASTM D5682, *Standard Test Methods for Electrical Resistivity of Liquid Paint and Related Materials*

