



Standard Test Method for Determination of Emittance of Materials Near Room Temperature Using Portable Emissometers¹

This standard is issued under the fixed designation C 1371; the number immediately following the designation indicates the year of original adoption or, in the case of revision, the year of last revision. A number in parentheses indicates the year of last reappraisal. A superscript epsilon (ϵ) indicates an editorial change since the last revision or reappraisal.

1. Scope

1.1 This test method covers a technique for determination of the emittance of typical materials using a portable differential thermopile emissometer. The purpose of the test method is to provide a comparative means of quantifying the emittance of opaque, highly thermally conductive materials near room temperature as a parameter in evaluating temperatures, heat flows, and derived thermal resistances of materials.

1.2 This test method does not supplant Test Method C 835, which is an absolute method for determination of total hemispherical emittance, or Test Method E 408, which includes two comparative methods for determination of total normal emittance. Because of the unique construction of the portable emissometer, it can be calibrated to measure the total hemispherical emittance. This is supported by comparison of emissometer measurements with those of Test Method C 835 (1).²

1.3 *This standard does not purport to address all of the safety concerns, if any, associated with its use. It is the responsibility of the user of this standard to establish appropriate safety and health practices and determine the applicability of regulatory limitations prior to use.*

2. Referenced Documents

2.1 ASTM Standards:³

- C 168 Terminology Relating to Thermal Insulation
- C 680 Practice for Estimate of the Heat Gain or Loss and the Surface Temperatures of Insulated Flat, Cylindrical, and Spherical Systems by Use of Computer Programs
- C 835 Test Method for Total Hemispherical Emittance of Surfaces up to 1400°C

¹ This test method is under the jurisdiction of ASTM Committee C16 on Thermal Insulation and is the direct responsibility of Subcommittee C16.30 on Thermal Measurement.

Current edition approved April 1, 2004. Published May 2004. Originally approved in 1997. Last previous edition approved in 1998 as C 1371 - 98.

² The boldface numbers in parentheses refer to the list of references at the end of this standard.

³ For referenced ASTM standards, visit the ASTM website, www.astm.org, or contact ASTM Customer Service at service@astm.org. For *Annual Book of ASTM Standards* volume information, refer to the standard's Document Summary page on the ASTM website.

- E 177 Practice for Use of the Terms Precision and Bias in ASTM Test Methods
- E 408 Test Methods for Total Normal Emittance of Surfaces Using Inspection-Meter Techniques
- E 691 Practice for Conducting an Interlaboratory Study to Determine the Precision of a Test Method

3. Terminology

3.1 *Definitions*—For definitions of some terms used in this test method, refer to Terminology C 168.

3.2 *Definitions of Terms Specific to This Standard:*

3.2.1 *diffuse surface*—a surface that emits or reflects equal radiation intensity, or both, into all directions (2).

3.2.2 *emissive power*—the rate of radiative energy emission per unit area from a surface (2).

3.2.3 *emissometer*—an instrument used for measurement of emittance.

3.2.4 *Lambert's cosine law*—the mathematical relation describing the variation of emissive power from a diffuse surface as varying with the cosine of the angle measured away from the normal of the surface (2).

3.2.5 *normal emittance*—the directional emittance perpendicular to the surface.

3.2.6 *radiative intensity*—radiative energy passing through an area per unit solid angle, per unit of the area projected normal to the direction of passage, and per unit time (2).

3.2.7 *spectral*—having a dependence on wavelength; radiation within a narrow region of wavelength (2).

3.2.8 *specular surface*—mirrorlike in reflection behavior (2).

3.3 *Symbols: Symbols:*

3.3.1 For standard symbols used in this test method, see Terminology C 168. Additional symbols are listed here:

α = total absorptance, dimensionless

α_λ = spectral absorptance, dimensionless

ϵ_{hi} = total emittance of the high-emittance calibration standard, dimensionless

ϵ_{low} = total emittance of the low-emittance calibration standard, dimensionless

ϵ_{spec} = apparent total emittance of the test specimen, dimensionless

ϵ = apparent total emittance of the surface, dimensionless

- ϵ_1 = apparent total emittance of the surface 1, dimensionless
- ϵ_2 = apparent total emittance of the surface 2, dimensionless
- ϵ_d = apparent total emittance of the surface of detector, dimensionless
- ϵ_s = apparent total emittance of the surface of specimen, dimensionless
- ϵ_λ = spectral emittance, dimensionless
- λ = wavelength, μm
- ρ = total reflectance, dimensionless
- σ = Stefan-Boltzmann constant, $5.6696 \times 10^{-8} \text{ W/m}^2 \cdot \text{K}$
- τ = total transmittance, dimensionless
- A = area of surface, m^2
- k = proportionality constant, $\text{V} \cdot \text{m}^2/\text{W}$
- Q_{rad} = radiation heat transfer, W
- q_{rad} = radiative heat flux, W/m^2
- T_1 = temperature of the test surface, K
- T_2 = temperature of the radiant background, K
- T_d = temperature of the detector, K
- T_s = temperature of the surface of specimen, K
- V_{hi} = voltage output of the detector when stabilized on high-emittance calibration standard
- V_{low} = voltage output of the detector when stabilized on low-emittance calibration standard
- V_{spec} = voltage output of the detector when stabilized on test specimen

4. Summary of Test Method

4.1 This test method employs a differential thermopile emissometer for total hemispherical emittance measurements.

The detector thermopiles are heated in order to provide the necessary temperature difference between the detector and the surface.⁴ The differential thermopile consists of one thermopile that is covered with a black coating and one that is covered with a reflective coating. The instrument is calibrated using two standards, one with a high emittance and the other with a low emittance, which are placed on the flat surface of a heat sink (the stage) as shown in Fig. 1. A specimen of the test material is placed on the stage and its emittance is quantified by comparison to the emittances of the standards. The calibration shall be checked repeatedly during the test as prescribed in 7.2.

5. Significance and Use

5.1 Surface Emittance Testing:

5.1.1 Thermal radiation heat transfer is reduced if the surface of a material has a low emittance. Since the controlling factor in the use of insulation is sometimes condensation control or personnel protection, it is important to note that a low emittance will also change the surface temperature of a material. One possible criterion in the selection of these materials is the question of the effect of aging on the surface emittance. If the initial low surface emittance of a material is

⁴ The sole source of supply of emissometers known to the committee at this time is Devices & Services Co., 10024 Monroe Drive, Dallas, TX 75229. If you are aware of alternative suppliers, please provide this information to ASTM Headquarters. Your comments will receive careful consideration at a meeting of the responsible technical committee, which you may attend.

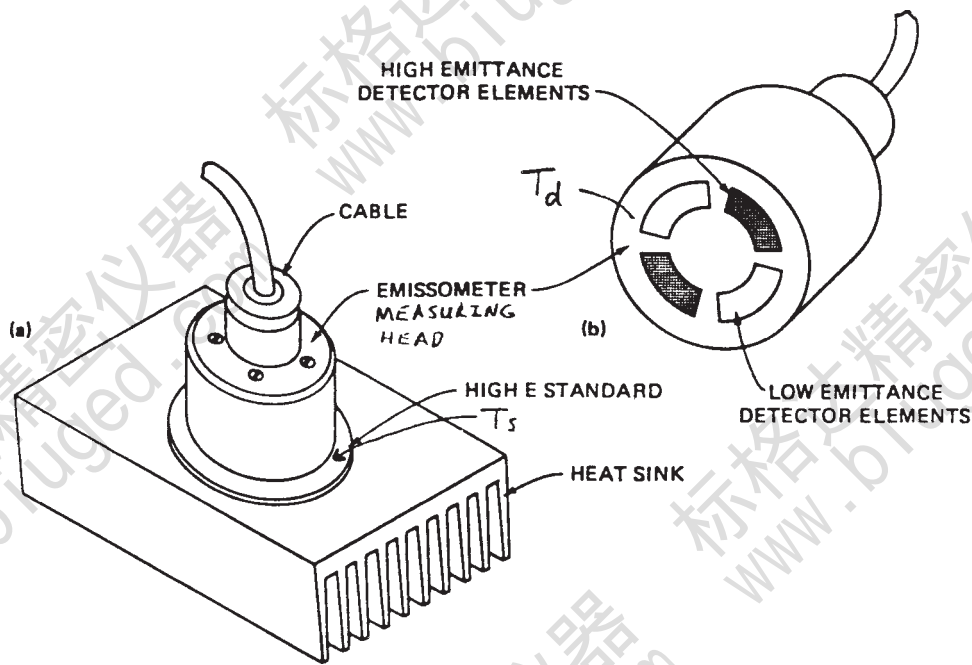

NOTE 1—(a) Emissometer measuring head on high-emittance standard during calibration, showing heat sink and cable to readout device. (b) Bottom view of emissometer measuring head showing high- and low-emittance detector elements. The diameter of the emissometer measuring head is about 50 mm and the detector elements are recessed about 3 mm into the measuring head.

FIG. 1 Schematic of Emissometer

not maintained during service, then the long-term value of the material is diminished.

5.1.2 This test method provides a means for comparative periodic testing of low emittance surfaces in the field. In this way the effects of aging on the reflective properties can be monitored.

5.1.3 This test method can be used to measure the total hemispherical emittance with a precision of better than ± 0.02 units, if some care is taken to avoid potential misapplications. (1) The emittances of the calibration standards shall have been obtained from accurate independent measurements of total hemispherical emittance. This test method shall not be used for specimens that are highly anisotropic or transparent to infrared radiation. This test method also shall not be used for specimens with significant thermal resistance (see 7.3.4).

5.1.4 Once a reliable emittance measurement has been determined, the value can be applied to calculate radiative heat flow from the subject surface. For example, if the temperature of the surface, T_1 , and the temperature of the surroundings, T_2 , are known, then the radiative heat flow, Q_{rad} , is given by:

$$Q_{\text{rad}} = A \epsilon \sigma (T_1^4 - T_2^4) \quad (1)$$

where A is the area of the surface, and either A is assumed to be much smaller than the area of the surroundings or the emittance of the surroundings is assumed to be unity. If desired, this radiative heat flow can be combined with convective heat flow to calculate the total heat flow from the surface (a method which is sometimes appropriate is described in Practice C 680).

6. Apparatus

6.1 This test method applies only to emittance tests conducted by means of a heated, differential thermopile emissometer, such as that shown in Fig. 1. The following elements are used:

6.1.1 *Differential Thermopile Radiant Energy Detector*—The differential thermopile consists of elements with high and low emittance that produce an output voltage proportional to the temperature difference caused by different amounts of thermal energy emitted and absorbed by each. The output voltage is proportional to the emittance of the surface that the detector faces.

6.1.2 *Controlled Heater*—Within the emissometer measuring head that maintains the head at a temperature above that of the specimen or calibration standard.

6.1.3 *Readout Device*—Typically a digital millivoltmeter, and sometimes includes a means of conditioning the thermopile output signal so that the emittance can be read directly.

NOTE 1—The emissometer⁴ has a direct readout of emittance, with a resolution of ± 0.01 units. For the work described in Ref (1), the resolution was increased to ± 0.001 units.

6.1.4 *Heat Sink Stage*—A heat sink with a flat surface or stage upon which the reference standards and specimen are placed, and which provides a means of maintaining the standards and specimen at the same, stable temperature.

6.1.5 *Reference Standards*—the manufacturer of the emissometer⁴ supplies two sets of reference standards, each set consisting of a polished stainless steel standard (emittance

about 0.06) and a blackened standard (emittance about 0.9). The standards shall be traceable to measurements made using an absolute test method (for example, Test Method C 835). It is recommended that one set be used as working standards and the other set be put aside and used for periodic checks of the emittance of the working standards. The time period between checks of the working standards will depend upon the amount that the working standards are used.

6.1.6 *Sample of the Surface to be Tested*, collected carefully so as to preserve the in-situ surface condition. A specimen slightly larger than the outer dimensions of the emissometer measuring head is carefully cut from the sample.

7. Procedure

7.1 *Set-up*—A sample of the material to be tested shall be collected as near as possible to the time of the test, to control sample conditioning history. The emissometer shall be allowed to equilibrate until the calibrations remain stable, with no drift. For measurements in the field, the emissometer shall be set up as near as possible to the sample size.

NOTE 2—For the emissometer⁴ a warm-up time of 1 h has been found to be acceptable.

7.2 Instrument Calibration:

7.2.1 Place the high- and low-emittance standards on the heat sink. Thermal contact between the standards and the heat sink is improved by filling the air gaps between the standards and the heat sink with distilled water or other high conductance material.

7.2.2 Place the emissometer measuring head over the high-emittance standard. Allow at least 90 s for the reading to stabilize.

7.2.2.1 If a standard millivoltmeter is used as the readout device, record the output voltage.

7.2.2.2 If the emittance is read out directly, use the variable gain control on the readout device to adjust the readout to be equal to the emittance of the high-emittance standard.

7.2.3 Place the emissometer measuring head over the low-emittance standard, and again allow at least 90 s for the reading to stabilize.

7.2.3.1 If a standard millivoltmeter is used as the readout device, calculate the expected reading from the low-emittance standard by means of (Eq 2) (see Section 8). Then adjust the offset trimmer on the emissometer until the readout value agrees with the calculated reading.

7.2.3.2 If the emittance is read out directly, use the offset trimmer control on the emissometer to adjust the readout to be equal to the emittance of the low-emittance standard.

7.2.4 Place the emissometer measuring head over the high-emittance standard again, and repeat the procedure in 7.2.1-7.2.3, until the measuring head can be moved from one standard to the other without requiring any adjustment to obtain the expected reading.

NOTE 3—Devices & Services Co.⁴ suggests that for best accuracy when evaluating low-emittance specimens (ϵ below about 0.2), a high-emittance standard shall be used that is in about the same emittance range as the specimen (3). In general, the closer the emittance of the high-emittance reference standard is to that of the specimen, the less the detector will overshoot, and the accuracy of the measurements will be improved.

7.3 Specimen Collection:

7.3.1 Since many different kinds of materials can be tested by means of this technique, different specimen collection procedures might be required, depending on the nature of the material. In general, the procedure shall ensure minimum alteration of the specimen surface. For example, if the emittance of a dust-covered specimen is desired, the dust shall not be removed.

7.3.2 All contact with the specimen surface shall be avoided. Furthermore, the specimen surface shall not be exposed to a flow of gas or liquid that is not ordinarily present as installed. If power tools are used, care shall be taken to prevent disturbance of any surface deposit layer (dust, etc.) due to vibration. Handling and time lag before emittance measurement shall be minimized.

7.3.3 The specimen shall be flat to within 0.25 mm over an area equal to that of the emissometer measuring head.

7.3.4 The specimen thermal conductance (that is, thermal conductivity divided by specimen thickness) shall be greater than 1100 W/m²·K, corresponding to a thermal resistance of less than 0.00091 m²·K/W. For example, if the specimen material is glass, with a thermal conductivity of about 1.0 W/m·K, then the specimen thickness shall be less than 0.91 mm.

7.4 *Measurement of Specimen Emittance*—The procedure given in 7.4.1-7.4.4.2 shall be used to measure the emittance of the specimen of material.

7.4.1 Recheck the emissometer calibration as per 7.2.

7.4.2 Leave the high-emittance standard in place, but remove the low-emittance standard from the heat sink and replace it with the specimen. For non-hygroscopic specimens, a few drops of distilled water or other high conductance material shall be used to improve the thermal contact between the specimen and the heat sink. Do not use water with hygroscopic specimens, such as paper. Allow at least 90 s for temperatures to stabilize.

7.4.3 Place the emissometer measuring head over the high-emittance standard, and wait for the output reading to stabilize. If a standard millivoltmeter is used, record the output voltage reading.

7.4.4 Place the emissometer measuring head over the specimen, and wait for the output reading to stabilize.

7.4.4.1 If the emittance is read out directly, record the value for the specimen.

7.4.4.2 If a standard millivoltmeter is used, the emittance of the specimen shall be calculated using (Eq 3).

8. Calculations

8.1 The expected reading of low emittance standard (standard millivoltmeter) is given by:

$$V_{\text{low}} = \epsilon_{\text{low}} \times V_{\text{hi}} / \epsilon_{\text{hi}} \quad (2)$$

8.2 The emittance of specimen (standard millivoltmeter) is given by:

$$\epsilon_{\text{spec}} = V_{\text{spec}} \times \epsilon_{\text{hi}} / V_{\text{hi}} \quad (3)$$

9. Report

9.1 The report of the results of each test shall have all data be reported in SI units. Report the following information:

9.1.1 Name and any other pertinent identification of the material, including a physical description.

9.1.2 Description of the specimen and its relationship to the sample, including a brief history of the specimen, if known.

9.1.3 Thickness of the specimen as received and as tested.

9.1.4 Temperature of the room in which the measurements were conducted, °C.

9.1.5 Source and assigned emittance values of the calibration standards.

9.1.6 Measured values of emittance. Two measured values shall be reported to demonstrate repeatability of the particular instrument for the particular type of surface.

9.1.7 Date of the test, and time periods involved in the test.

9.1.8 Statement of compliance or, where circumstances or requirements preclude complete compliance with the procedures of the test, agreed exceptions. A suggested wording is: "This test conformed with all requirements of ASTM C 1371 with the exception of (a complete list of exceptions follows)."

9.1.9 Estimated or calculated uncertainty in reported values.

10. Precision and Bias

10.1 *Interlaboratory Test Program*—An informal interlaboratory comparison was conducted during 1988 and 1989 (1). Specimens of Type 304L stainless steel ($\epsilon \sim 0.12$) and electrolytic tough pitch copper ($\epsilon \sim 0.04$) were specially prepared.

10.1.1 Test determinations were made on one specimen of each material at one laboratory on 23 different days spanning a time period of about one year. On each day, two test determinations were made by a single operator on each specimen, for a total of 46 test results per material. Another specimen of each material was prepared. A single operator at the same laboratory made two test determinations on each specimen on one day. A single operator at another laboratory made two test determinations on each specimen on one day and four test determinations on each specimen three days later. Yet another specimen of each material was prepared. A single operator at the first laboratory made two test determinations on each specimen on one day. A single operator at a third laboratory made four test determinations on each specimen on one day. These data were analyzed by the methods given in Practice E 691 to determine repeatability and reproducibility limits. The fact that many of the test determinations were made over an extended period of time was ignored in this analysis.

10.1.2 Additional specimens of stainless steel and copper were prepared. Each specimen was measured at the first laboratory using an emissometer. The first laboratory also measured the total hemispherical emittance of a specimen of stainless steel using Test Method C 835. Three other laboratories used absolute techniques to determine the total hemispherical emittance of each of the materials. The techniques were a calorimeter, a reflectometer, and an infrared thermometer.

10.2 *Test Result*—Each separate test determination from the three laboratories was treated as a test result, for a total of 60 test results per material.

10.3 *Precision*—The numerical values are in dimensionless emittance units. Repeatability limit and reproducibility limit are used as specified in Practice E 177. The respective standard deviations among test results is obtained by dividing the above limit values by 2.8.

95 % repeatability limit (within laboratory)	Stainless Steel 0.011 units	Copper 0.015 units
95 % reproducibility limit (between laboratories)	0.015 units	0.019 units

10.4 *Bias*—Statistical analyses were performed on the results of paired measurements by the emissometer and the

absolute techniques. Separate analyses were performed for the stainless steel and copper specimens. The analyses showed no statistically significant difference (at the 5 % significance level) between the average values obtained with the emissometer and the absolute techniques. It is concluded that there is no statistically significant bias in this test method.

11. Keywords

11.1 emissometer; emittance; portable

APPENDIX

(Nonmandatory Information)

X1. HEMISPHERICAL EMITTANCE MEASUREMENTS

X1.1 Because of the application to aging of reflective insulations, there is considerable interest in employing this test method for measurements of hemispherical emittance. This appendix details the pros and cons of using the test method to quantify hemispherical emittance.

X1.1.1 This test method is different from either of two other techniques (Test Method C 835 and Test Method E 408) for measurement of hemispherical emittance. Instruments for measuring hemispherical emittance typically comprise an enclosed highly reflective envelope, the only absorbing/emitting surfaces being the specimen and the detector or flux source, or both. Alternatively, the specimen is heated, and the total flux through the specimen is measured. The manufacturer of the one instrument known to conform to this test method intended for their instrument to measure the total hemispherical emittance, but because of the directional properties of many real surfaces (especially metals), the property that is measured is somewhere between the hemispherical and normal emittance values (4).

X1.1.2 Note that the detector plane is parallel to the plane of the specimen in Fig. X1.1. For the instrument of this test method, the source of emitted thermal energy is the exposed surface of the detector itself, and the heat flow is from the detector surface to the specimen surface. Since the absolute temperature of the detector is known and the heat flow is measured—and since the instrument is calibrated against standards of known emittance, at the same temperature as a test specimen—the emittance of the test specimen can be solved from:

$$V = k \times \sigma \left(\frac{T_s^4 - T_d^4}{(1/\epsilon_s + 1/\epsilon_d - 1)} \right) \tag{X1.1}$$

where *k* is a proportionality constant.

X1.1.3 The arrangement of the detector is such that its voltage response is a function of its own diffuse radiation of heat energy (5), and that the emitted radiation is attenuated by the energy reflected from the specimen surface over a detector

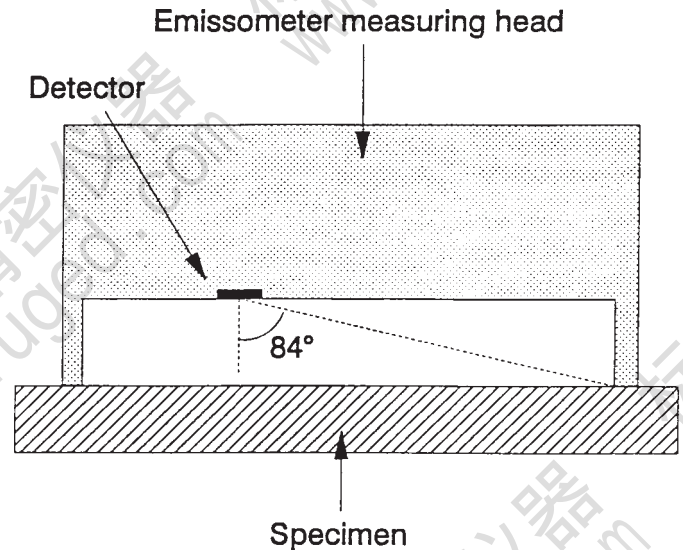
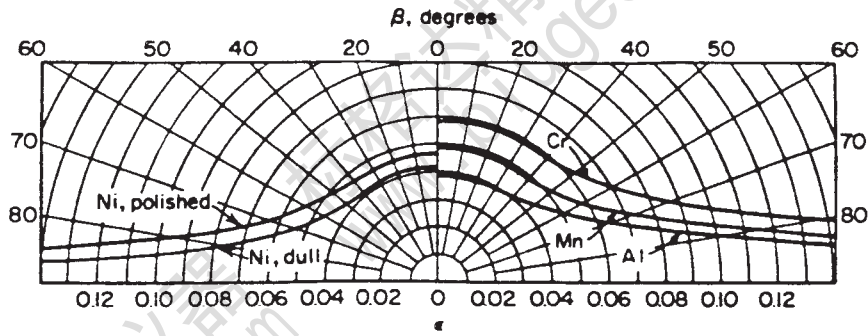

FIG. X1.1 Cross-section of Emissometer Measuring Head, Showing Plane Angle Subtended by Detector Element

exposure angle of about 168–169° (± about 84° from normal). This is illustrated in Fig. X1.1.

X1.1.4 Fig. X1.2(a) shows the directional emittance of some smooth metal surfaces, while Fig. X1.2(b) shows a similar plot for some dielectric materials (6). Note that for aluminum, the emittance is about 0.04 for angles of 0 to about 38° from normal. For angles greater than 38° from normal, the emittance increases, reaching about 0.14 at an angle of about 83° from normal. The average of the integral of this curve (the hemispherical emittance) appears to be about 0.057—a difference of almost 42 % from the normal emittance. This high degree of sensitivity to direction signifies the existence of a large specular component to the reflectance of such a surface (there will be some diffuse emittance/reflectance, as well).

X1.1.5 For aluminum oxide, the directional emittance is about 0.82 at the normal angle, rises to a peak of probably about 0.83 at 45° from normal, and then declines to around 0.74 at an angle of around 85° from normal. The hemispherical



(a)

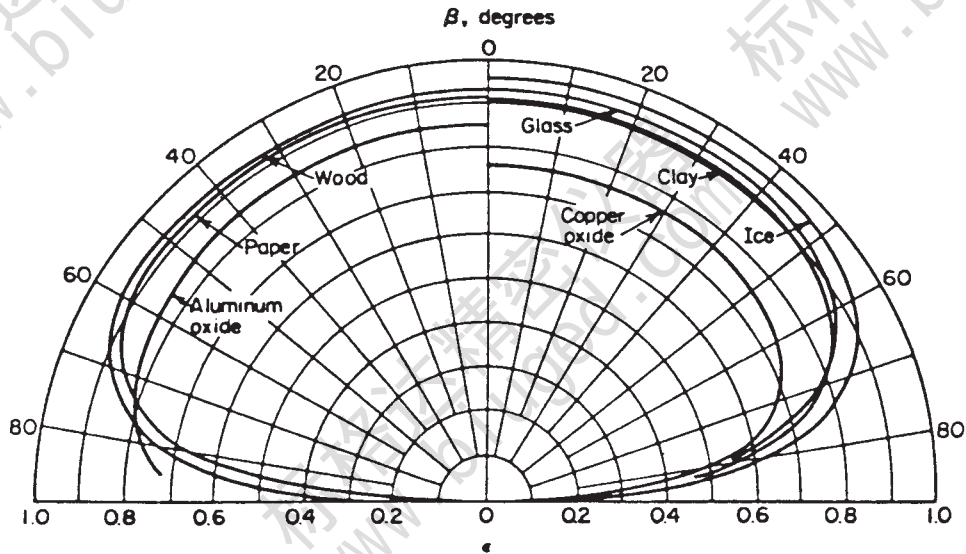

(b)

NOTE 1—(a) Electrical conductors, (b) electrical nonconductors (6).

FIG. X1.2 Directional Emittance of Selected Materials

emittance would appear to be around 0.813—a difference from the normal emittance of only 2%. This nearly constant distribution is a good example of a material which is mainly diffuse (that is, it obeys Lambert's cosine law).

X1.1.6 Since the detector/heat source plane is all heated and parallel to the specimen plane (and since the specimen temperature is uniform) the radiation emitted by the detector will primarily be normal to the specimen. Because the detector surface coating is highly diffuse, however, some of the radiation leaving the detector area will reach the unheated wall of the emissometer measuring head. Because the inner surface of this wall is also dull and diffuse, most of this direct irradiation from the detector will be absorbed by the wall, effecting a bias error. The calibration process will tend to eliminate this error, as this bias will be the same for both the calibration standards and the test specimens.

X1.1.7 The next step is to consider what happens to the radiant energy that strikes the specimen surface. The general radiant energy balance equation illustrates that for any test surface of emittance less than 1.0, a fraction of the energy radiated from the detector will be reflected from the specimen surface.

$$\alpha + \rho + \tau = 1 \tag{X1.2}$$

where:

- α = absorptance,
- ρ = reflectance, and
- τ = transmittance.

For simplification, by considering only those materials which are opaque to infrared radiation ($\tau = 0$), the energy balance reduces to:

$$\alpha + \rho = 1 \quad (X1.3)$$

so that only the energy absorbed by the specimen and the energy reflected by the specimen need to be considered for a full accounting of the energy emitted by the detector. Furthermore, Kirchoff's Radiation Law states that, at thermal equilibrium:

$$\alpha_\lambda = \epsilon_\lambda \quad (X1.4)$$

so that the fraction of the radiant energy absorbed by the specimen (compared to the energy that could be absorbed by a blackbody at the same temperature) is equal to the emittance of the specimen at these conditions.

X1.1.8 The detector cannot differentiate the amount of energy absorbed by the specimen from the total energy emitted by the detector. In fact, it is the total energy emitted by the detector that is evaluated to determine the emittance (absorptance) of the specimen. Basically, this works because the reflected energy from the specimen returns to the detector and is reabsorbed, so that the total detector radiated energy is reduced to the value necessary to calculate the correct specimen emittance. It can be easily seen that if some mechanism causes part of the reflected energy not to be returned to the detector, an error would result. A study of the radiant heat transfers in the instrument would reveal what conditions (if any) might cause such an error.

X1.1.9 Assuming a detector temperature of 355.4 K (180°F) and a specimen temperature of 295.4 K (72°F), (Eq 1) indicates:

$$q_{\text{rad}} = 5.6696 \times 10^{-8} \times (355.4^4 - 295.4^4) = 472.8 \text{ W/m}^2 \quad (X1.5)$$

for blackbody exchange between the two surfaces. If the specimen emittance is actually 0.90, only 90 % of this energy will actually be absorbed; the remainder will be reflected from the specimen. Therefore, $0.90 \times 472.8 = 425.5 \text{ W/m}^2$ (7) will be absorbed, and $472.8 - 425.5 = 47.3 \text{ W/m}^2$ (8) will be reflected. If the specimen is perfectly specular, all this energy will be reflected back into the detector, effecting a 10 % reduction in the total heat flow through the thermopile (90° incident radiation will be reflected at 90°).

X1.1.10 On the other hand, if the specimen is more a diffuse emitter/reflector, some of the energy which is reflected from that part of the specimen surface directly beneath the detector will be reflected away from the detector. At first, this might seem to present a potential source of error. However, the diameter of the specimen is much larger than the diameter of the detector, and the detector is imbedded flush in the center of a plane which is also heated, and which has the same emittance as the detector itself. This arrangement serves somewhat as a "guard" for the detector, such that reflected energy lost due to the diffuseness of the specimen surface immediately beneath the detector is compensated for by the diffuse component of

reflected energy from the outer portion of the specimen surface (the source of this energy being the heated guard area around the detector).

X1.1.11 For the case where the instrument is calibrated using specular standards (those normally supplied) but where the specimen is diffuse, because energy reflected from the standards will mainly be reflected back directly onto the detector plane, there will be little bias error intrinsic to the calibration. If the instrument is calibrated to the normal emittance of the standards, very little measurement error will occur for normal emittance measurements on the test specimen, since any energy loss due to diffuse reflection from the surface immediately under the detector will be compensated for by the energy reflected diffusely from the annular area immediately surrounding. On the other hand, if the instrument is calibrated to the hemispherical emittance value of the specular standards, it still measures only a portion of the energy which relates more to hemispherical emittance from the detector, attenuated by reflectance from the specimen over a 169° exposure. If there is significant reflectance or emittance from the standards in the region 85–90° from normal (from Fig. X1.2(a)), we see that this apparently occurs with some shiny metals), then calibration to the known hemispherical emittance values of the standards will be accomplished by correcting the instrument to account for lost hemispherical energy. If the instrument is then used to measure the emittance of a diffuse specimen, the reflected energy actually returning to the detector will be somewhat higher than expected, and the output of the instrument will contain a low bias error. This error might occur on aged aluminum reflective insulations or jacketing or on diffuse reflective paints and coatings, wherein the existing hemispherical emittance might be measured as a value below the true hemispherical emittance.

X1.1.12 An even greater error might occur with either specular or diffuse standards if the specimen is directionally specular, that is, if the sample emits or reflects non-diffusely, or both, but at some angle far from normal to the surface as is exhibited by some machined surfaces. This has been confirmed by the results of one test conducted on a stainless steel disk that was grooved and polished on one side and smooth but not highly polished on the other side. The smooth, not highly polished side of the disk was resolved at about $\epsilon = 0.16$ by three laboratories, while the grooved-and-polished side read about $\epsilon = 0.46$. The detector could only "see" the grooved side as a higher emittance because the detector received a lower reflected energy from the grooved side of the specimen—the specimen reflected the detector's emitted energy away, toward the walls. A true hemispherical device would have recaptured this energy and redirected it to the detector to correctly attenuate the heat flow and the detector output voltage (this effect can be seen mathematically in (Eq 1)). The correct hemispherical emittance would then have been resolved at approximately $1.23 \times 0.16 = 0.20$ (1) (maximum, since the smooth back surface was not polished). (Note that the 0.46 value was probably close to the correct normal emittance for this specimen.)

REFERENCES

- (1) Kollie, T. G., Weaver, F. J., and McElroy, D. L., "Evaluation of a Commercial, Portable, Ambient-Temperature Emissometer," *Rev. Sci. Instrum.*, Vol 61, 1990, pp. 1509–1517.
- (2) Siegel, R., and Howell, J. R., *Thermal Radiation Heat Transfer*, 2nd Ed., McGraw-Hill, New York, NY, 1981.
- (3) Anonymous, *Measurements of Low Emittance Materials with the Model AE Emissometer*, Technical Note 84-3, Devices & Services Co., Dallas, TX, 1984.
- (4) Moore, C., Devices & Services, Inc., private communication with K. Wilkes, June 21, 1994.
- (5) Anonymous, *Emissometer Model AE*, Technical Note 78-2, Devices & Services Co., Dallas, Texas, 1978.
- (6) Schmidt, E. and Eckert, E., "Über die Richtungsverteilung der Wärmestrahlung von Oberflächen," *Forsch. Geb. Ingenieurwes.*, Vol 6, 1935, pp. 175–183, as quoted in *Handbook of Heat Transfer*, Section 15, edited by W. M. Rohsenow and J. P. Hartnett, McGraw-Hill, New York, NY, 1973.
- (7) Holman, J. B., *Heat Transfer*, 4th Ed., McGraw-Hill, New York, NY, 1976, p. 13.
- (8) Kreith, F. and Bohn, M. S., *Principles of Heat Transfer*, 4th ed., Harper & Row, New York, NY, 1986, p. 442.

ASTM International takes no position respecting the validity of any patent rights asserted in connection with any item mentioned in this standard. Users of this standard are expressly advised that determination of the validity of any such patent rights, and the risk of infringement of such rights, are entirely their own responsibility.

This standard is subject to revision at any time by the responsible technical committee and must be reviewed every five years and if not revised, either reapproved or withdrawn. Your comments are invited either for revision of this standard or for additional standards and should be addressed to ASTM International Headquarters. Your comments will receive careful consideration at a meeting of the responsible technical committee, which you may attend. If you feel that your comments have not received a fair hearing you should make your views known to the ASTM Committee on Standards, at the address shown below.

This standard is copyrighted by ASTM International, 100 Barr Harbor Drive, PO Box C700, West Conshohocken, PA 19428-2959, United States. Individual reprints (single or multiple copies) of this standard may be obtained by contacting ASTM at the above address or at 610-832-9585 (phone), 610-832-9555 (fax), or service@astm.org (e-mail); or through the ASTM website (www.astm.org).